

MAKE: LANDROVER

TYPE: Discovery



MODEL: Series I



YEAR: 1991 – 03/1999

DETAIL:

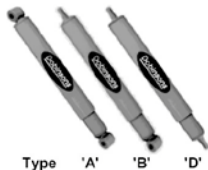
LAND-55



FRONT		TYPE	QTY	PART NUMBER
COIL SPRING Type 'C' 				
	Linear Rate Standard Height (20mm Lift)		1	C51-016 (Pair)
	Linear Rate Raised Height (45mm Lift)		1	C51-014 (Pair)
	Linear Rate Raised Height (40mm Lift) Diesel Engine Up to 50Kg Accessories		1	C51-018 (Pair)
SHOCK ABSORBER 				
	Heavy Duty Gas	D	2	GS51-116
STEERING DAMPER 				
	Type 'A' Heavy Duty (Big Bore) Complete with Fittings	A	1	SD51-811
UNDER BODY BUSH KIT 				
	Polyurethane Bush			
NOTE: See Rear Under Body Bush Kit				
CASTOR KIT Front Leading Arm Castor Kit ($\pm 2^\circ$) Kit Contains: 4 x Eccentric Polyurethane Bushes (Suit 44mm wide Leading Arm)				
		-	1	PB51-502K
Raising vehicle will affect castor angle. A wheel alignment is recommended to determine if a castor kit is required. Note: Do Not fit to Automatic Models as Vibration may occur				

REAR		TYPE	QTY	PART NUMBER
COIL SPRING Type 'C' 				
	Variable Rate Standard Height (20mm Lift)		1	C51-023V (Pair)
	Linear Rate Raised Height (35mm Lift)		1	C51-015 (Pair)
	Linear Rate Raised Height (50mm Lift)		1	C51-022 (Pair)
	Variable Rate Raised Height (50mm Lift) Extra Heavy Duty 220Kg to GVM		1	C51-027V (Pair)
SHOCK ABSORBER 				
	Heavy Duty Gas	C	2	GS51-117
UNDER BODY BUSH KIT 				
	Polyurethane Bush			
NOTE: Kit Includes Front & Rear Under Body Bushes				
	2 x Front Panhard Rod Bush 4 x Front Radius Arm to Diff Bush 4 x Front Radius Arm to Chassis Bush 2 x Rear Upper Arm to Chassis Bush 2 x Rear Lower Arm to Diff Bush 4 x Rear Lower Arm to Chassis Bush	-	1	PB51-1243K