

MAKE: FORD

TYPE: Ranger





MODEL: PJ





YEAR: 2007 on

DETAIL: Pickup / Dual Cab
Mazda BT-50

FORD-60

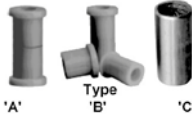

 FRONT 	TYPE	QTY	PART NUMBER
<p>TORSION BAR</p>  <p>Type 'D'</p> <p>Heavy Duty Rate Increased Length 1024mm x 27mm</p>	D	1	TB39-1551 (Pair)
<p>SHOCK ABSORBER</p>  <p>Type 'A' 'B' 'C'</p> <p>Heavy Duty Gas</p>	B	2	GS19-082P

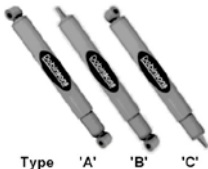
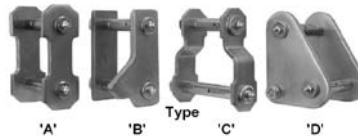
 REAR 	TYPE	QTY	PART NUMBER
<p>LEAF SPRING</p>  <p>Type 'B'</p> <p>Standard Duty 3 + 2 Leaves Raised Height (40mm Lift) Light Load to GVM</p> <p>B 2 L39-030-R</p> <p>Heavy Duty 4 + 2 Leaves Raised Height (45mm Lift) 280Kg to GVM</p> <p>B 2 L39-031-R</p> <p>Super Heavy Duty 5 + 2 Leaves Raised Height (40mm Lift) 420Kg to GVM</p> <p>B 2 L39-032-R</p>			
<p>SHACKLE BUSH KIT</p> <p>Rubber Polyurethane Metal</p>  <p>'A' Type 'B' 'C'</p> <p>Kit Contains: 2 x PB59-1503 4 x SPF502 4 x SPF753</p> <p>B 1 PB39-1056K</p>			
<p>U-BOLT KIT</p>  <p>Type 'A' 'B' 'C'</p> <p>Kit Contains: 2 x UB21-466</p> <p>A 2 UB21-466K</p>			
<p>SHOCK ABSORBER</p>  <p>Type 'A' 'B' 'C'</p> <p>Heavy Duty Gas</p> <p>A 2 GS19-081T</p>			
<p>SHACKLE KIT</p>  <p>'A' 'B' Type 'C' 'D'</p> <p>Greasable: Fit in Pairs</p> <p>C 2 SK59-010</p>			